

# Bambu Lab X1E Combo 3D Printer

## Quick Start

Please review the entire guide before operating the printer.

- \* Safety Notice: Do not connect to power until assembly is complete.

PF001-E

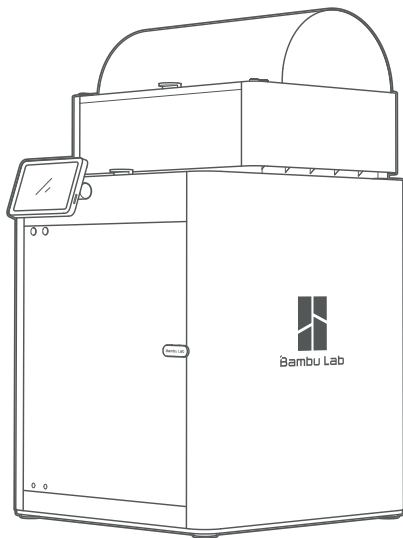





**Bambu Lab Wiki**  
<https://wiki.bambulab.com>

---

## \*Warning:

- When operating the AMS, we recommend using Bambu Filament, which has been thoroughly tested to work with the AMS.
- **Please make sure to avoid using soft materials like TPU or damp PVA, as they can get stuck in the AMS.**
- AMS supports spool width of 50 mm - 68 mm. We highly recommend using filament with plastic spools that fit correctly inside the AMS. If you prefer to use cardboard spools, we strongly advise using a spool adapter to reduce the risk of slippage and debris getting left behind in the AMS.
- If you run into any issues with specific filaments, please let us know so that we can provide better advices to our community.



## Component Introduction

---

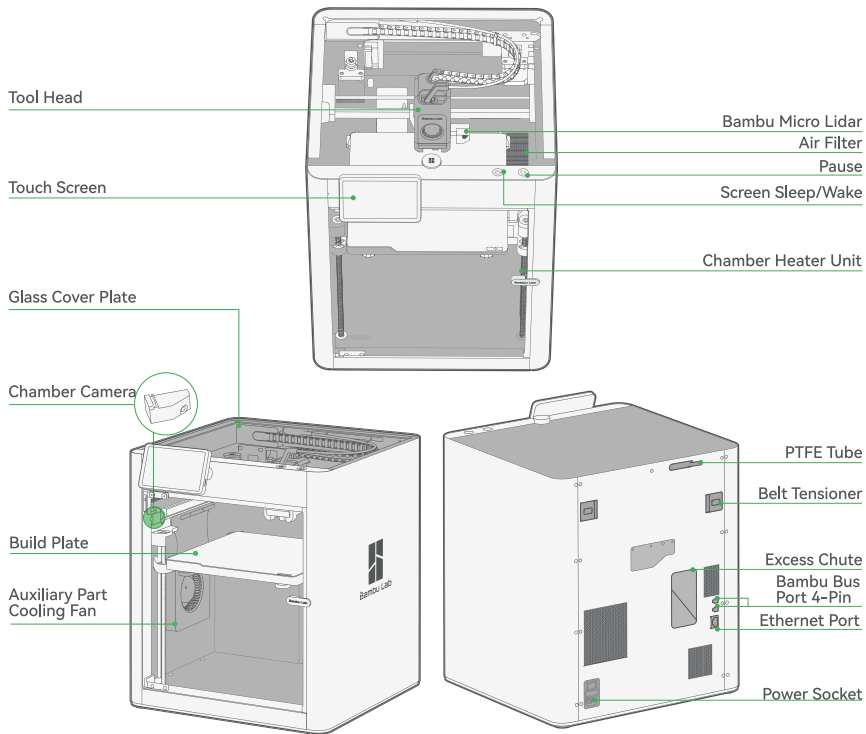

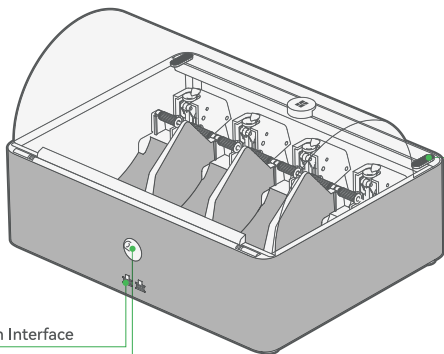

Buckle

Bambu Bus Cable 6-Pin Interface

Filament Outlet

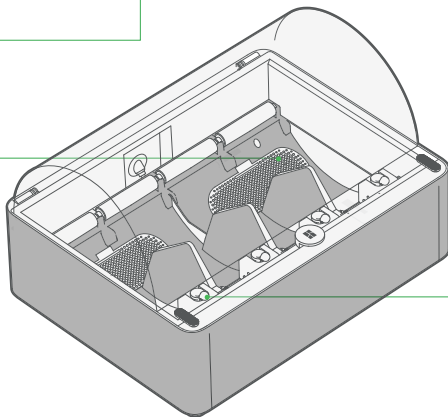

Desiccant

Filament Inlet

## Accessory Specification

---

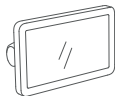

Touch Screen



Spool Holder

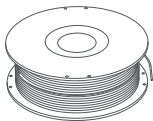

Filament (x3)



Complete Hot End Assembly



Nozzle Wiping Pad (x2)

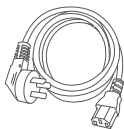

Power Cord



Spare Filament Cutter (x2)

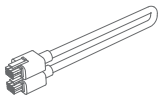

Bambu Bus Cable-6Pin



Allen Key H1.5  
Allen Key H2



Unclogging Pin  
Tool



Flexible Build Plate  
(Pre-installed on  
build plate)

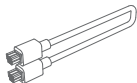

Bambu Bus Cable-4Pin



Bambu Scraper



Glue for Build Plate

## AMS & Tool Head Unlock

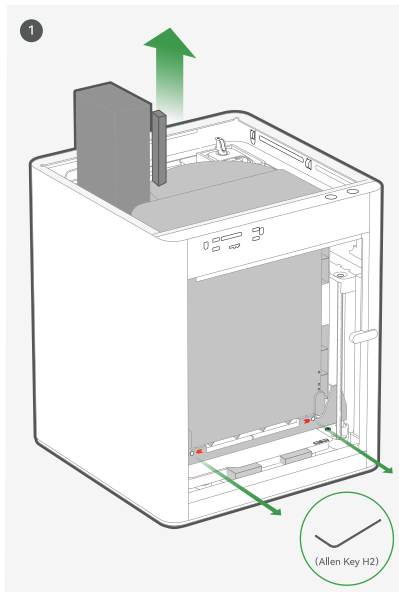

Take out the accessory box and filament switches.

\*We recommend using the short end of the Allen Key to unlock the screws more easily.

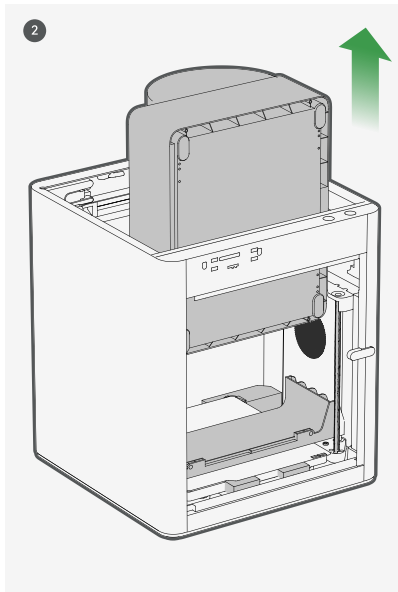

Take out the AMS by sliding it out through the top.



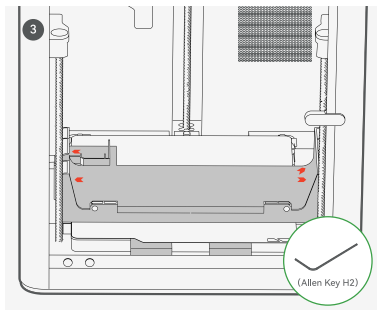

Remove the four screws as the arrows indicate.

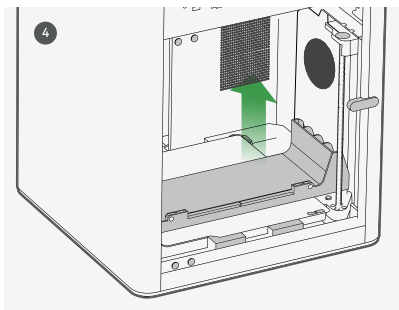

Take out the AMS cushioning.

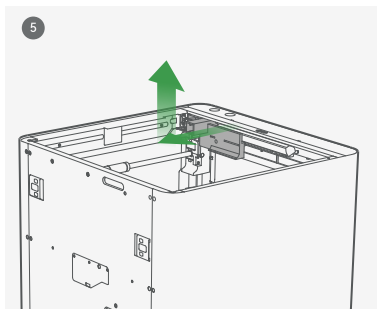

Take out the cushioning.

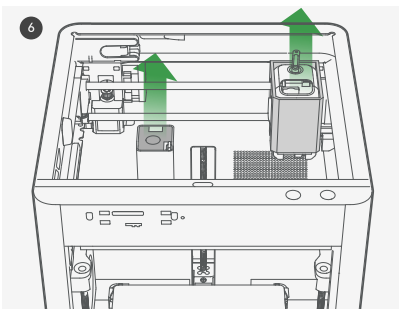

Remove the cardboard from the tool head.  
Remove the foam from the excess chute.

## AMS Assembly

\*The cable-6pin can be plugged into either interface.

550mm PTFE Tube

370mm PTFE Tube

Bambu Bus Cable-6Pin

Bambu Bus Cable-4Pin

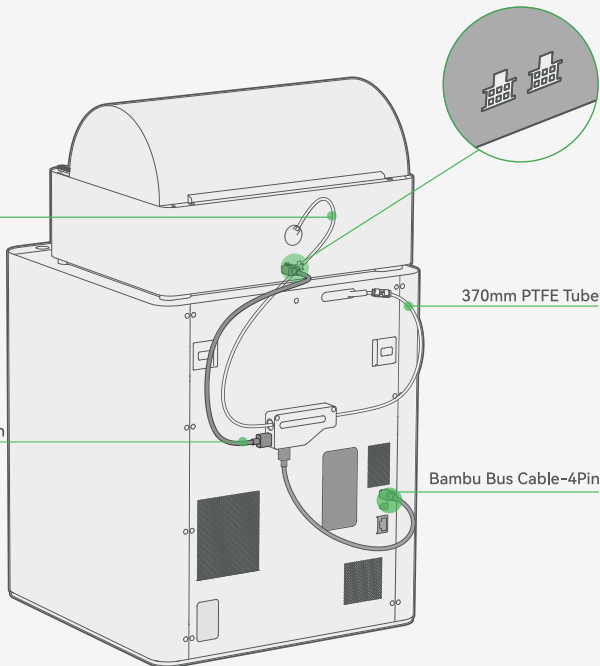

## Spool Holder Assembly

---

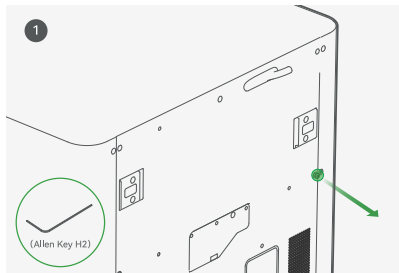

Remove the screw as pictured with an Allen Key H2.

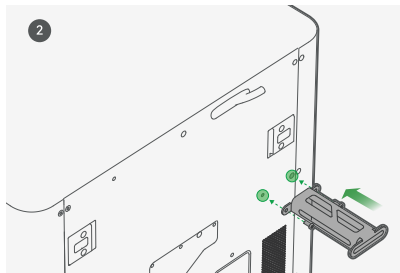

Secure the spool holder with two screws from the accessory box.

## Hot Bed Unlock & Screen Installation

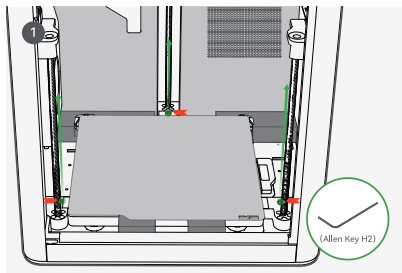

Remove the three screws with an Allen Key H2 to unlock the hot bed.

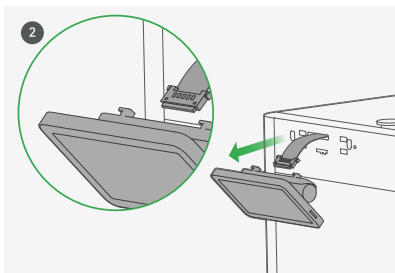

Pull the Flexible Printed Circuit (FPC) out about 50mm.

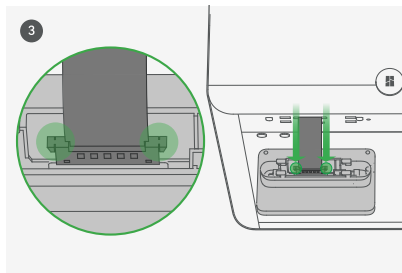

Insert the FPC into the port by pressing the terminal as pictured.

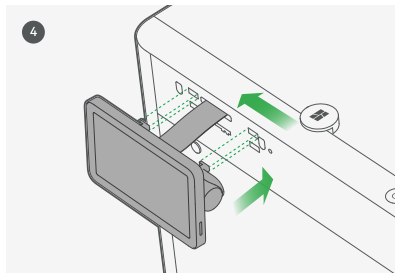

Insert the screen back to the slot on the printer, then lock it by pushing it to the left.

## Connectivity

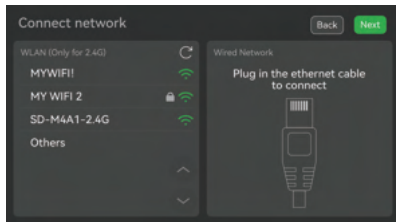

X1E now supports both Wi-Fi and Wired connection.

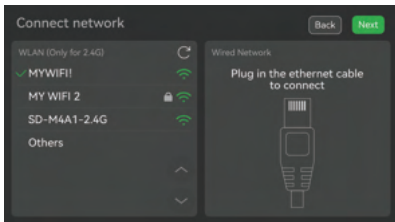

**Wi-Fi connection:** Select your preferred Wi-Fi to connect with Wi-Fi. The connected Wi-Fi network shows a checkmark on the left.



**Ethernet connection:** Plug-in the Ethernet cable to connect with Ethernet. The connected status shows on the screen as the diagram.

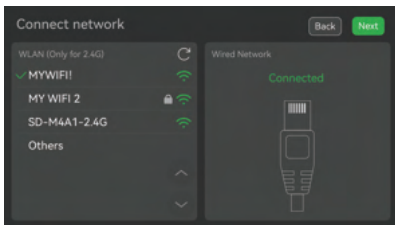

**Both:** You can connect with both Wi-Fi and Ethernet. (Ethernet connection is prioritized)

## Network Kill Switch

---

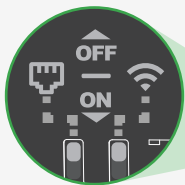

2. There are 2 separate switches to physically turn off the Ethernet and Wi-Fi.

1. Peel out the cover at the left upper side of the X1E frame.

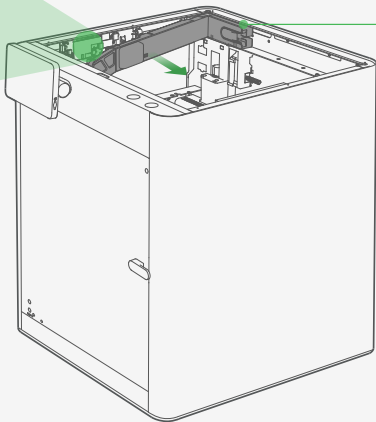

# Printer Binding

1. Download the Bambu Handy App. Register and log in to your Bambu Lab account.
2. Connect the printer to power. Follow the instructions on the screen until getting to the page shown on the right side.



3. Use Bambu Handy to scan the QR code on the screen, and bind your printer with your Bambu Lab account.

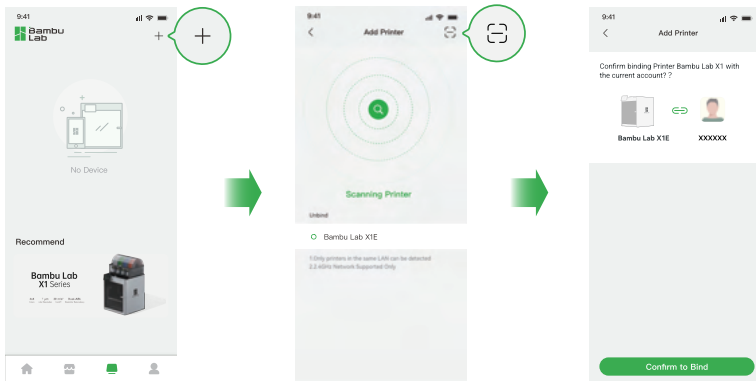

4. Follow the instructions on the screen to complete the initial calibration. It is normal to have vibration and noise during the calibration process.  
**DO NOT** remove the protective foam from beneath the hot bed until after the initial calibration is complete.

## First Print

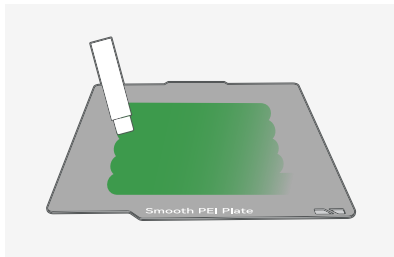
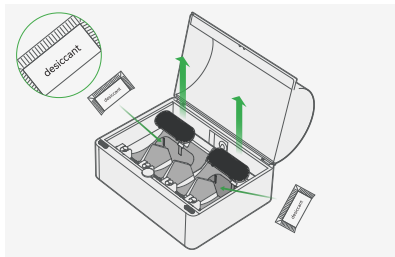

Apply a thin layer of glue on the build plate.

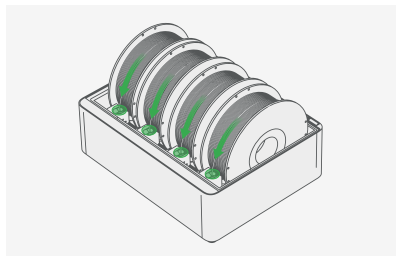

Place at least one spool of Bambu Filament into the AMS. Turn on the power to start the printer and the AMS. Insert the filament into the filament inlet. The filament will be automatically pre-loaded when detected.

\*We recommend first printing a single-color model with the supplied Bambu PLA Basic.

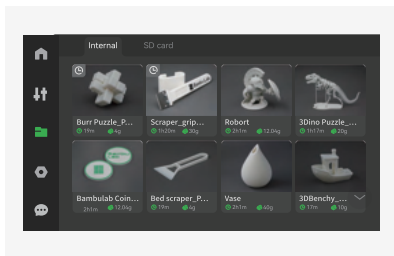

Press "  " - "internal". Select a file to start the first print.

\*We recommend using one of the pre-loaded files as a first test print.



# Bambu Studio

Download Bambu Studio: <http://bambulab.com/download>

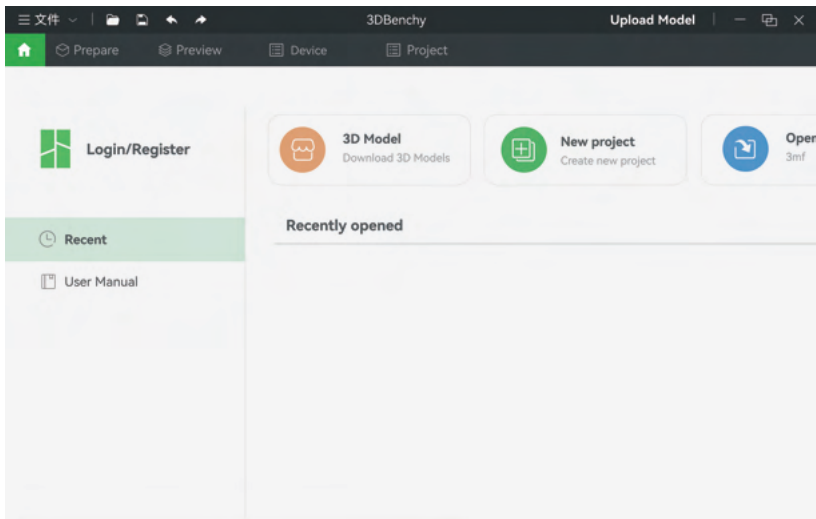

Log in to Bambu Studio with your Bambu Lab account, which is the same for the Bambu Online store. Create or open a project.

# Bambu Studio

The screenshot shows the Bambu Studio interface with a 'Send print job to' dialog box open. The dialog displays a 3D model of a yellow part, the filament type 'PLA', and the printer 'Bambu Lab X1E'. The printer is selected in the 'Printer' dropdown. The background shows the main software interface with various settings panels like 'Printer', 'Filament', 'Process', 'Quality', and 'Seam'.

**Send print job to**

38h06s 11.57 g

Printer: Bambu Lab X1E

Bed leveling  Flow Dynamics Calibrat...

Timelapse

[Can't connect to the printer](#)

Send

**Printer**

Bambu Lab X1E 0.4 nozzle

Plate type: Smooth PEI Plate

**Filament**

Bambu PLA Basic

**Process**

0.20mm Standard @0BL X1E

**Quality**

Strength Speed Support Others

**Layer height**

Layer height: 0.2 mm

First layer height: 0.2 mm

**Line width**

Default: 0.42 mm

First layer: 0.5 mm

Outer wall: 0.42 mm

Inner wall: 0.65 mm

Top surface: 0.42 mm

Sparse infill: 0.65 mm

Internal solid infill: 0.42 mm

Support: 0.42 mm

**Seam**

**Order scheme**

Line Type	Time	Percent	Display
Inner wall	5m15s	13.7%	
Outer wall	8m32s	22.7%	
Overhang wall	4s	0.2%	
Sparse infill	3m37s	10.0%	
Internal solid infill	1m53s	5.9%	
Top surface	3m3s	9.0%	
Bottom surface	19s	0.6%	
Bridge	1m35s	4.5%	
Gap infill	2m18s	6.0%	
Custom	4m54s	14.1%	
Travel	6m7s	18.0%	
Retract			
Unretract			
Wipe			
Seam			

Total estimation

Filament: 3.82 m 11.57 g

Cost: 0.29

Prepare time: 4m05s

Model printing time: 37m46s

Total time: 38h06s

Size complete

Slice the model, select your printer and send the model to print.

\*We recommend performing bed leveling before each print and performing flow calibration after changing filament.

# Bambu Studio

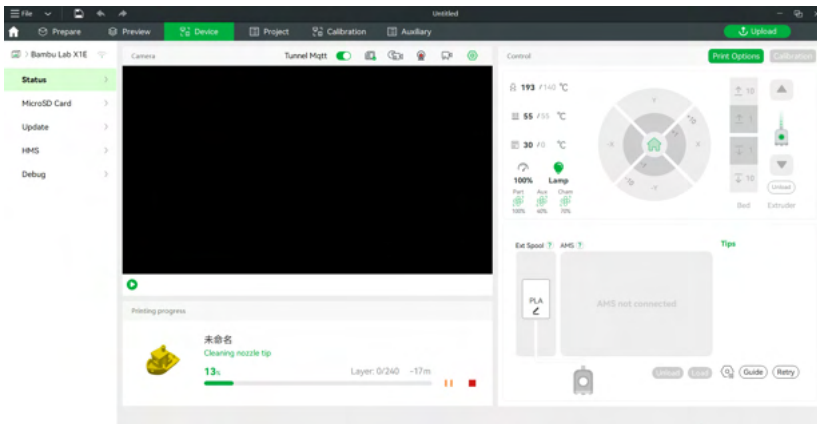

During printing, you can remotely monitor your print, or pause/stop printing on the "Device" interface.

\*The live view can be seen only if a camera is mounted.



**Bambu Studio**  
**Bambu Handy**

<https://bambulab.com/download>

# Specification

Item		Specification
Printing Technology		X1E Fused Deposition Modeling
Body	Build Volume(W×D×H)	256*256*256 mm <sup>3</sup>
	Chassis	Steel
	Shell	Aluminum & Glass
Supported Filament	PLA, PETG, TPU, PVA, BVOH	Optimal
	ABS, ASA, PC, PA, PET	Superior
	Carbon/Glass Fiber Reinforced PLA, PETG, PA, PET, PC, ABS, ASA	Superior
	PPA-CF/GF, PPS, PPS-CF/GF	Ideal
Heating	Active Chamber Heating	Yes
	Maximum Chamber Control Temperature	60°C
Air Purification	Pre-filter Grade	G3
	HEPA Filter Grade	H12
	Activated Carbon Filter Type	Coconut Shell Granulated
	VOC Filtration	Optimal
	Particulate Matter Filtration	Yes
Network Control	Ethernet	Yes
	Wireless Network	Wi-Fi
	Network Kill Switch	Wi-Fi & Ethernet
	Removable Network Module	Yes
	802.1X Network Access Control	Yes
Cooling	Part Cooling Fan	Closed Loop Control
	Hot End Fan	Closed Loop Control
	Control Board Fan	Closed Loop Control
	Chamber Temperature Regulator Fan	Closed Loop Control
	Auxiliary Part Cooling Fan	Closed Loop Control
Hot bed	Build Plate	Flexible Steel Plate
	Build Plate Surface (Included)	Bambu Smooth PEI Plate
	Build Plate Surface (Optional)	Bambu High Temperature Plate, Bambu Textured PEI Plate, Bambu Cool Plate
	Max Build Plate Temperature	110°C@220V, 120°C@110V
Speed	Max Speed of Tool Head	500 mm/s
	Max Acceleration of Tool Head	20 m/s <sup>2</sup>
	Max Hot End Flow	32 mm <sup>3</sup> /s @ABS(Model: 150*150mm single wall, Material: Bambu ABS, Temperature: 280°C)

<b>Tool Head</b>	Hot End	All-Metal
	Extruder Gears	Hardened Steel
	Nozzle	Hardened Steel
	Max Hot End Temperature	320 °C
	Nozzle Diameter (Included)	0.4 mm
	Nozzle Diameter (Optional)	0.2 mm, 0.6 mm, 0.8 mm
	Filament Cutter	Yes
<b>Sensors</b>	Filament Diameter	1.75 mm
	Bambu Micro Lidar	Yes
	Chamber Monitoring Camera	1920*1080 Included
	Door Sensor	Yes
	Filament Run Out Sensor	Yes
	Filament Odometry	Optional with AMS
	Power Loss Recover	Yes
<b>Physical Dimensions</b>	Dimensions	389*389*457mm
	Net Weight	16kg
<b>Electrical Requirements</b>	Voltage	100-240 VAC, 50/60 Hz
	Max Power	1400W@220V, 750W@110V
<b>Electronics</b>	Display	5-inch 1280*720 Touch Screen
	Storage	4GB EMMC and Micro SD Card Reader
	Control Interface	Touch Screen, APP, PC Application
	Motion Controller	Dual-Core Cortex M4
	Application Processor	Quad ARM A7 1.2 GHz
	Neural-Network Processing Unit	2 Tops
<b>Software</b>	Slicer	Bambu Studio Support third party slicers which export standard G-code such as SuperSlicer, PrusaSlicer and Cura, but certain advanced features may not be supported.
	Slicer Supported OS	MacOS, Windows
<b>Wi-Fi</b>	Frequency Range	2412 MHz - 2472 MHz (CE) 2412 MHz - 2462 MHz (FCC) 2400 MHz - 2483.5 MHz (SRRC)
	Transmitter Power (EIRP)	≤ 21.5 dBm (FCC) ≤ 20 dBm (CE/SRRC)
	Protocol	IEEE 802.11 b/g/n
<b>Ethernet</b>	Socket	RJ45
	Speed	100 Mbps / Full Duplex
<b>Laser (CLASS 1)</b>	Wavelength	850 nm, 850 nm
	Maximum Output of Laser Radiation	< 0.778 mW

## Customer Support

Please visit the Bambu Lab Wiki for more setup and maintenance tutorials.

<https://wiki.bambulab.com/en/home>



If you need support, please try either of the two approaches:

**Approach 1: Create a support ticket on the Official Website**

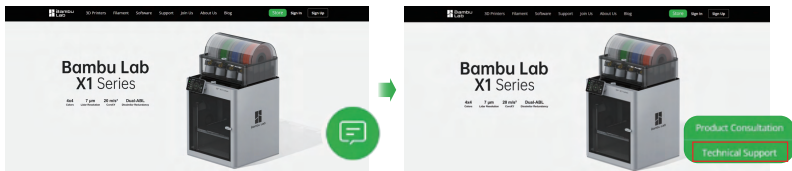

**Approach 2: Create a support ticket on the Bambu Handy App**

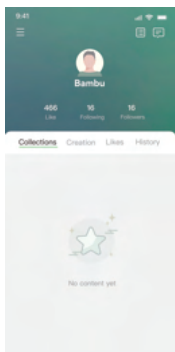





**Bambu Lab**

**Enjoy!**

[www.bambulab.com](http://www.bambulab.com)



# 骑马钉形式

材质：128g 哑粉纸

工艺：彩色印刷

尺寸：120\*120mm



PANTONE:447 C



PANTONE:354C



PANTONE:Bright Red C